

THINK | CLADDING | THINK

ALSTONE®

HELLO **FUTURE!**



THINK | CLADDING | THINK

ALSTONE[®]

T H E F U T U R E

O F E X T E R I O R C L A D D I N G



THE LEGACY OF
TWO DECADES OF
DELIVERING OVER 700+
MILLION SQ FT OF MCPs,
NOW DELIVERS EVEN MORE.

THINK **CLADDING** THINK

ALSTONE[®]



21+
YEARS OF
TRUST

700+
MILLION SQ FT
OF MCP DELIVERED

500+
CHANNEL
PARTNERS

300+
PRIMARY
SHADES

17
OFFICES
PAN INDIA

INTRODUCING

ALSTONE[®]
ALCOMB
Aluminium Honeycomb Panel

THE **FUTURE** OF EXTERIOR CLADDING

THINK **CLADDING** THINK

ALSTONE[®]

Alstone, a leading and trusted brand in the cladding industry, now introduces Aluminium Honeycomb Panels (AHP). The panel consists of lightweight structure of aluminium hexagonal cells, sandwiched between two thin aluminium sheets. This design offers exceptional strength-to-weight ratios, high rigidity and excellent wind pressure resistance. Alcomb is ideal for exterior cladding and a perfect solution to meet modern design challenges.

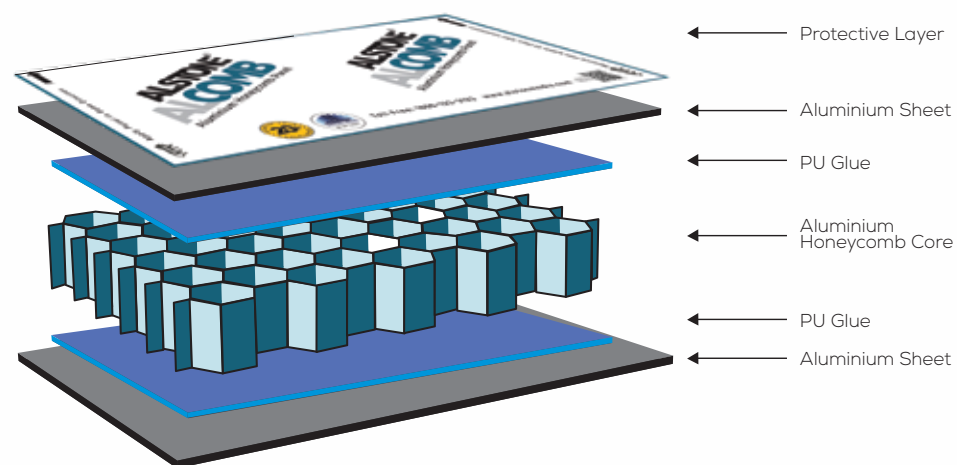
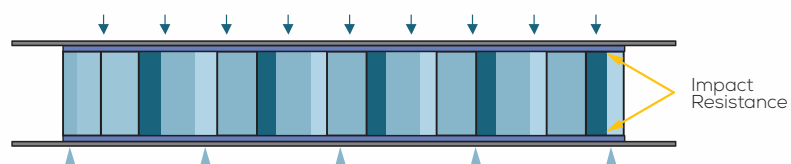

A P P L I C A T I O N S

ALSTONE[®]
ALCOMB
Aluminium Honeycomb Panel



BULLNOSE & COPING



EXTERIOR CLADDING



INTERIOR CEILING



INTERIOR CLADDING



CANOPY



SUN LOUVERS



THINK | CLADDING | THINK

ALSTONE[®]



WHY ALSTONE ALCOMB?

Certified By:



THE **FUTURE** OF EXTERIOR CLADDING

ALSTONE[®]
ALCOMB
Aluminium Honeycomb Panel



NON COMBUSTIBLE

Engineered with non-combustible materials, ensuring safety and compliance.
Certified by **THOMAS BELL WRIGHT**.



LIGHT WEIGHT

Despite its robust structure, the honeycomb panel is incredibly lightweight, which is great for transportation and installation.



HIGH STRENGTH

With exceptional high strength, Alcomb offers superior durability, standing up to extreme conditions.



100% SUSTAINABLE

These panels are 100% recyclable and composed of 98% aluminium, making them a LEED-certified product.



ACOUSTIC CAPABILITIES

The honeycomb design also offers excellent acoustic insulation, reducing noise levels to ensure a quieter environment.



SUPERIOR FLATNESS

With Alcomb panels, you can achieve perfect aesthetics with flawless flatness, ensuring a smooth, polished and pleasing appearance.

THINK | CLADDING | THINK

ALSTONE[®]

N O N C O M B U S T I B L E A 2 G R A D E

WE'RE COMMITTED TO SAFE BUILDINGS



Non Combustible, A2 Grade

Alcomb honeycomb panels, certified by **Thomas Bell Wright**, meet the stringent non-combustible A2 grade classification.

ALSTONE[®]
ALCOMB
Aluminium Honeycomb Panel

Certified by:



THINK | CLADDING | THINK

ALSTONE®



L I G H T W E I G H T

Light Weight

Alcomb honeycomb panels redefine lightweight construction without compromising strength. Their innovative core structure delivers an exceptional strength-to-weight ratio, offering architects and facade consultants unparalleled design flexibility.

ALSTONE[®]
ALCOMB
Aluminium Honeycomb Panel

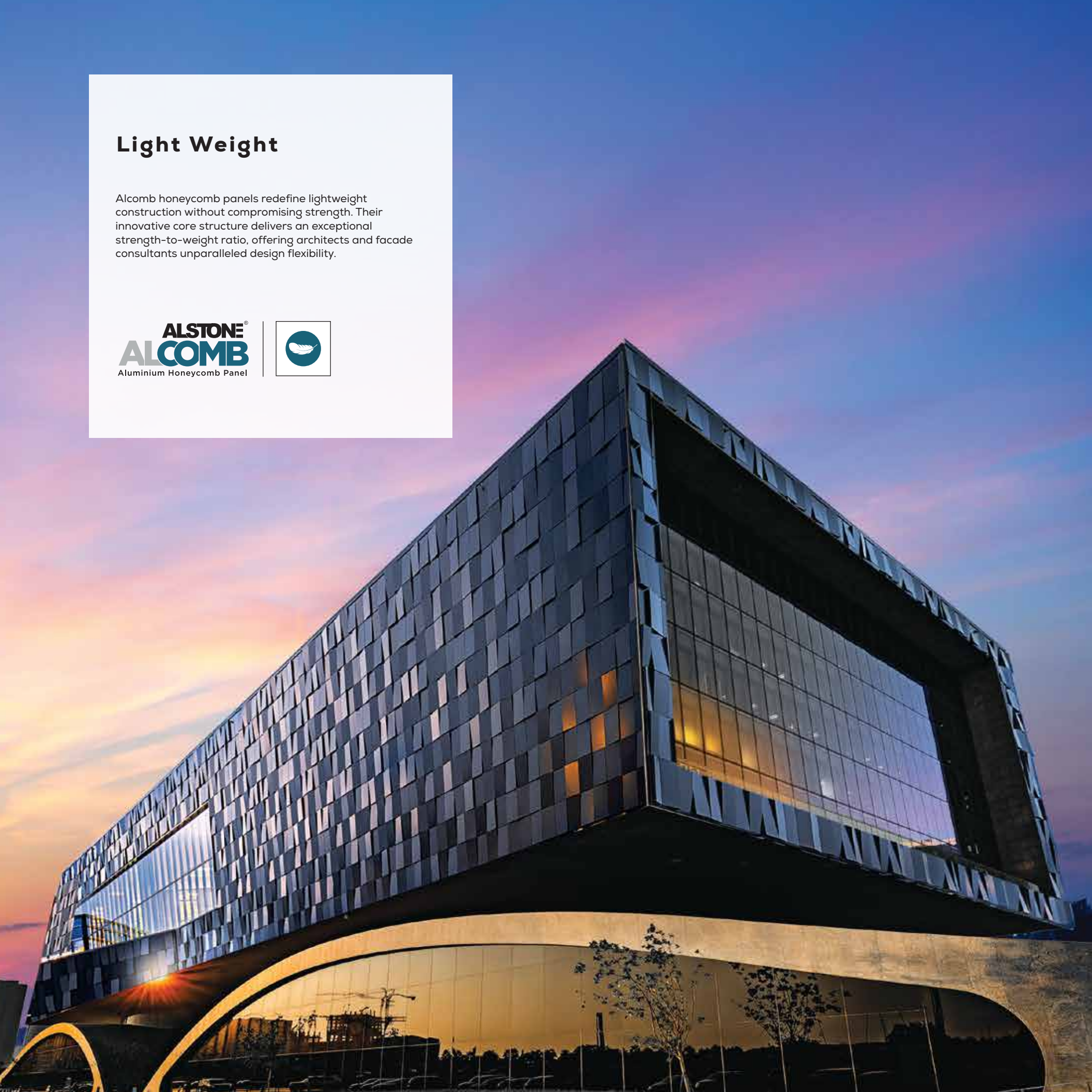

THINK | CLADDING | THINK

ALSTONE[®]



H I G H S T R E N G T H

High Strength

Alcomb Honeycomb Panels offer superior rigidity and load-bearing capacity, these panels enable architects and facade consultants to create more ambitious, durable structures. Their high strength-to-weight ratio allows for larger spans and enhanced longevity while resisting bending, wind, and environmental stresses.

ALSTONE[®]
ALCOMB
Aluminium Honeycomb Panel



THINK | CLADDING | THINK

ALSTONE[®]



1 0 0 % S U S T A I N A B L E

100% Sustainable

Alcomb honeycomb panels embody 100% sustainability, setting a new benchmark in eco-friendly construction materials. Fully recyclable and produced with minimal environmental impact, these panels align perfectly with green building initiatives. For architects and facade consultants committed to sustainability, Alcomb offers a responsible choice without compromising on performance or aesthetics.

ALSTONE[®]
ALCOMB
Aluminium Honeycomb Panel



THINK | CLADDING | THINK

ALSTONE[®]

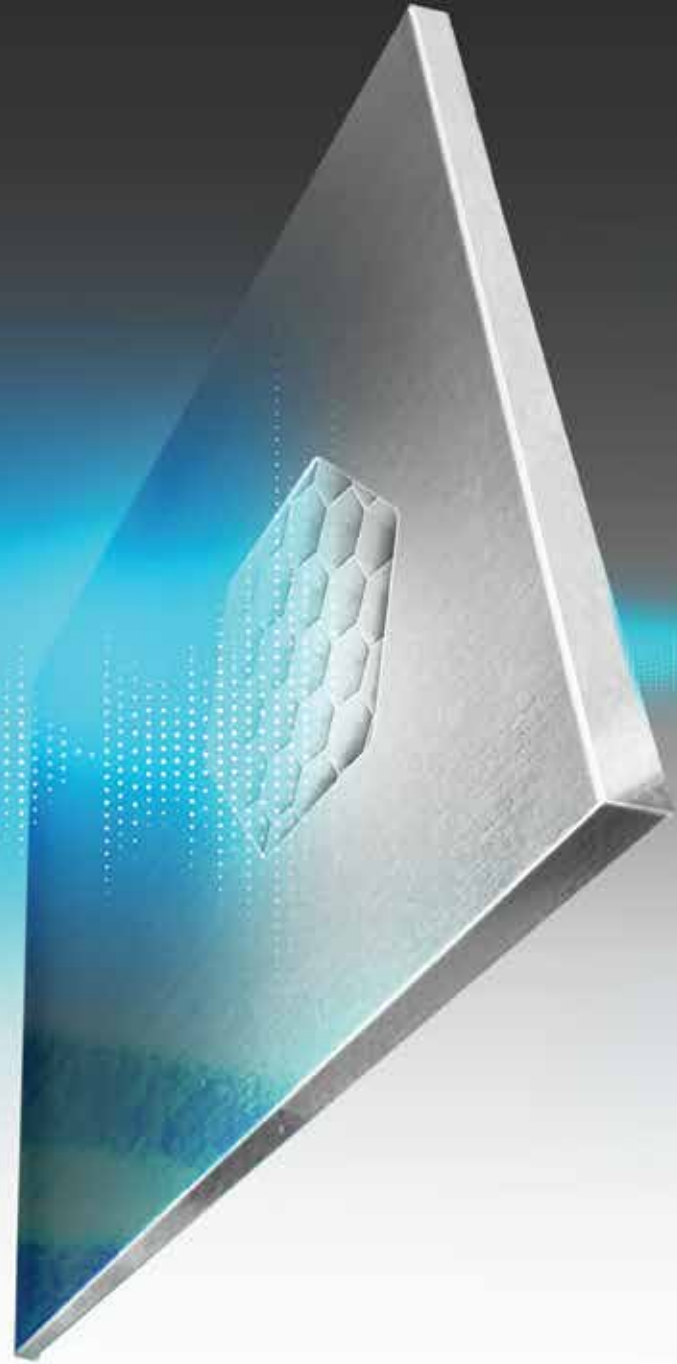

ACOUSTIC CAPABILITIES

Acoustic Capabilities

Alcomb Honeycomb offers superior sound absorption and insulation across a broad frequency spectrum, it excels in managing low-frequency NRC noise—a common challenge in modern buildings.

Customizable acoustic performance allows architects to precisely engineer sound environments, from private offices to pristine auditoriums.

ALSTONE[®]
ALCOMB
Aluminium Honeycomb Panel



THINK | CLADDING | THINK

ALSTONE®



S U P E R I O R F L A T N E S S

Superior Flatness

Alcomb honeycomb panels set the industry standard for superior flatness, offering architects and facade consultants unparalleled surface consistency. Their innovative core structure ensures minimal warping and deflection, even across large spans. This exceptional flatness enables seamless integration in modern designs, from sleek building facades to precision-dependent interiors.

ALSTONE[®]
ALCOMB
Aluminium Honeycomb Panel



THINK | CLADDING | THINK

ALSTONE[®]

**IMAGINE
ANY
COLOUR,**

AND ALSTONE DELIVERS IT!

THE **FUTURE** OF EXTERIOR CLADDING

ALSTONE[®]
ALCOMB
Aluminium Honeycomb Panel

CERTIFICATIONS

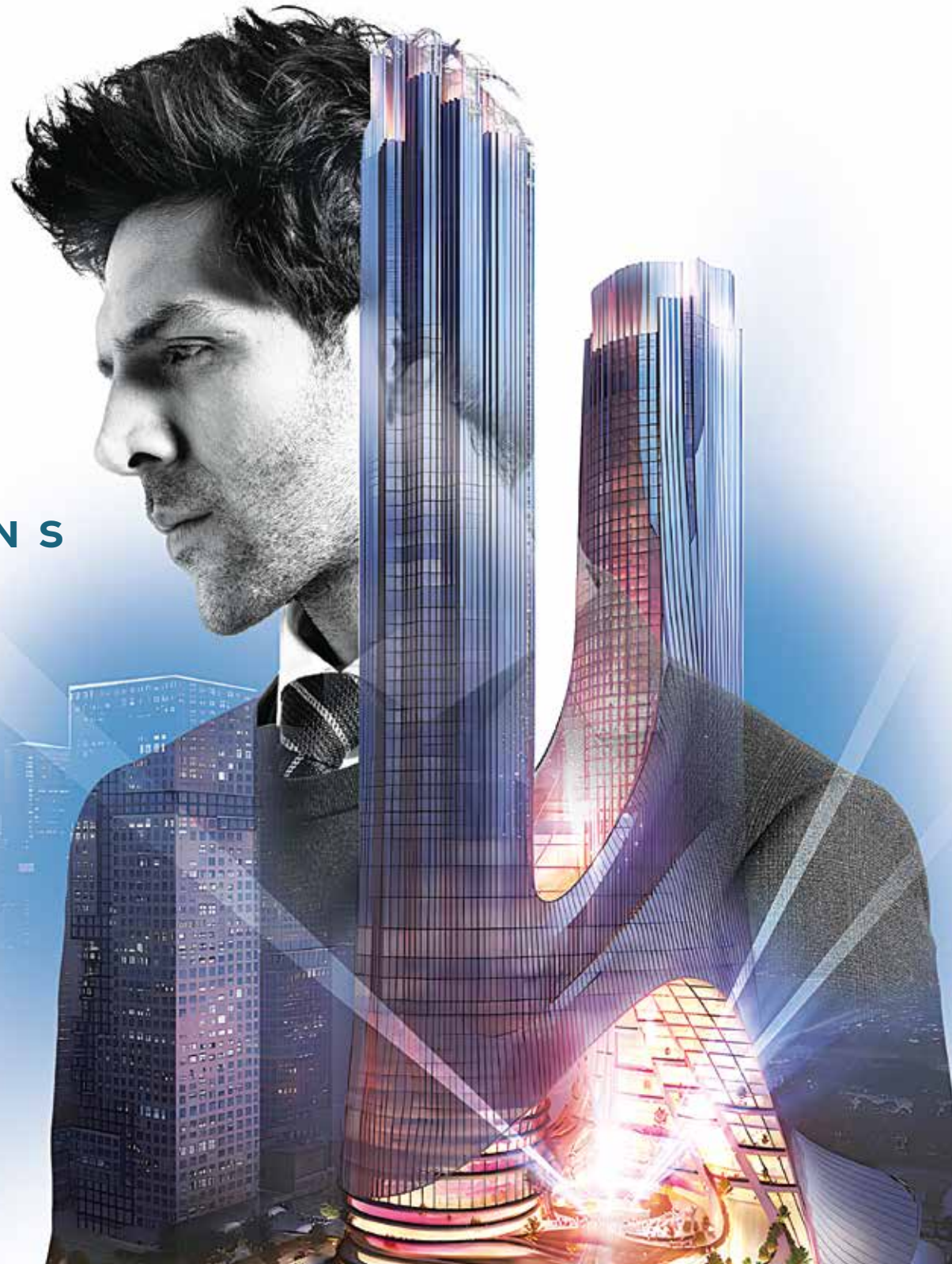



Dr. Jayant Jain
Professor

भारतीय प्रौद्योगिकी संस्थान दिल्ली
INDIAN INSTITUTE OF TECHNOLOGY DELHI
Department of Materials Science & Engineering
Hauz Khas, New Delhi - 110016, India
Tel. : +91-11-2659 1246
E-mail : jayantj@mse.iitd.ac.in
Web. : <https://sites.google.com/view/profjayantjain/home>

Date: 30-08-2024

Alstone Alcomb Panel, 12 mm thick

Sr.No	Mechanical property	Test method	Units	Results
1	Tensile Strength	ASTM E8	MPa	10.6
2	Yield strength	ASTM E8	MPa	10.26
3	Elongation	ASTM E8	%	5.57
4	Flexural Rigidity EI	DIN 53293	KNcm ² /m	20337
5	Section Modulus Z	DIN 53293	mm ³	588
6	Shear Punch Strength	ASTM D732	MPa	20.7
7	Flexural Strength	ASTM D7264	MPa	23.3
8	Compressive Strength	ASTM C365	MPa	1.26
9	Crush Strength	ASTM-C 365	MPa	1.05
10	Bonding Strength Between Foil	ASTM D1781	N/mm	1.21
11	Cell Size	Physical	Shape and size	Hexagonal, side length 6.5 mm
12	Alloy	--	Aluminum alloy	AA 3105
13	Foil Thickness	Physical	mm	0.70
14	Tensile Strength (Foil)	ASTM E8	MPa	179.4
15	Yield Strength (Foil)	ASTM E8	MPa	169
16	Elongation (Foil)	ASTM E8	%	11.1
17	Modulus of Elasticity (Foil)	ASTM E8	MPa	77481
18	Density	AMS-C 7438	g/cm ³	0.889
19	Inorganic Analysis by Xray Spectrometer (EDX Analysis)	ASTM E 1508	-	Al 97.3%, Mn 0.48%, Fe 0.35%, Mg 1.23%, Si 0.56%, Ti 0.08%
20	Thermal Resistance	-	K/W	0.00084
21	Thermal conductivity (k)	-	W/m-K	1.5
22	Heat Transition co-efficient (U)	-	W/m ² -K	5.62

Test results pertain only to samples submitted to us

Dr. Jayant Jain
Professor
Department of Materials Science & Engineering
Indian Institute of Technology Delhi
Hauz Khas, New Delhi-110016, India

Dr. Suresh Neelakantan
Associate Professor
Department of Materials Science & Engineering
Indian Institute of Technology Delhi
Hauz Khas, New Delhi-110016, India

Page 1 of 2



Dr. Jayant Jain
Professor

भारतीय प्रौद्योगिकी संस्थान दिल्ली
INDIAN INSTITUTE OF TECHNOLOGY DELHI
Department of Materials Science & Engineering
Hauz Khas, New Delhi - 110016, India
Tel. : +91-11-2659 1246
E-mail : jayantj@mse.iitd.ac.in
Web. : <https://sites.google.com/view/profjayantjain/home>

Date: 30-08-2024

Alstone Alcomb Panel, 25 mm thick

Sr.No	Mechanical property	Test method	Units	Results
1	Tensile Strength	ASTM E8	MPa	8.67
2	Yield strength	ASTM E8	MPa	8.51
3	Elongation	ASTM E8	%	6.6
4	Flexural Rigidity EI	DIN 53293	KNcm ² /m	10341
5	Section Modulus Z	DIN 53293	mm ³	2552.1
6	Shear Punch Strength	ASTM D732	MPa	19.5
7	Flexural Strength	ASTM D7264	MPa	4.78
8	Compressive Strength	ASTM C365	MPa	0.84
9	Crush Strength	ASTM-C 365	MPa	0.62
10	Bonding Strength Between Foil	ASTM D1781	N/mm	1.48
11	Cell Size	Physical	Shape and size	Hexagonal, side length 6.8 mm
12	Alloy	--	Aluminum alloy	AA 3105
13	Foil Thickness	Physical	mm	0.70
14	Tensile Strength (Foil)	ASTM E8	MPa	174.4
15	Yield Strength (Foil)	ASTM E8	MPa	167.3
16	Elongation (Foil)	ASTM E8	%	9.6
17	Modulus of Elasticity (Foil)	ASTM E8	MPa	71600
18	Density	AMS-C 7438	g/cm ³	0.645
19	Inorganic Analysis by Xray Spectrometer (EDX Analysis)	ASTM E 1508	-	Al 97.40%, Mn 0.46%, Fe 0.34%, Mg 1.24%, Si 0.49%, Cu 0.04%, Ti 0.02%
20	Thermal Resistance	-	K/W	0.0009
21	Thermal conductivity (k)	-	W/m-K	2.7
22	Heat Transition co-efficient (U)	-	W/m ² -K	5.58

Test results pertain only to samples submitted to us

Dr. Jayant Jain
Professor
Department of Materials Science & Engineering
Indian Institute of Technology Delhi
Hauz Khas, New Delhi-110016, India

Dr. Suresh Neelakantan
Associate Professor
Department of Materials Science & Engineering
Indian Institute of Technology Delhi
Hauz Khas, New Delhi-110016, India

Page 2 of 2

TEST CERTIFICATE

THOMAS BELL-WRIGHT
A FISHER GROUP COMPANY



In accordance with UKAS accreditation to ISO/IEC 17065
Certification is Hereby Granted
to

Alstone Manufacturing Pvt. Ltd.
15th Floor Vijaya Building, 17 Barakhamba Rd,
Connaught Place, 110001 New Delhi, India

for
“Alcomb”
Aluminium Honeycomb Core Composite Material
(Classified according to BS EN 13501-1:2018)

which, subject to limitations described on the following pages and continued
listing on www.tbwcert.com, complies with Product Certification Scheme
*SD03 Exterior Wall Assemblies, Curtain Walls, Building Materials,
Products & Assemblies*

In witness whereof, this Certificate is issued this 29th day of August 2024

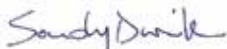

Sandy Dweik
Chief Executive Officer

Nicholas Purcell
Director of Certification

Certificate Number: TBW0301077

Initial registration: August 29, 2024 Issued: August 29, 2024 Expiration: August 28, 2027
File Name: YF132_CRT_SDO3RX_issue1_(f) Issue 1

This certificate and schedules are held in force by regular Factory Inspections by Thomas Bell-Wright International Consultants (TBWIC).
Refer to www.tbwcert.com or contact TBWIC Certification Division to validate the current status of the Certification.
This certificate remains a property of Thomas Bell-Wright International Consultants.
P.O. Box 20385, Dubai, UAE. | Tel: +971 4 825777 | Email: certification@bell-wright.com | Web: www.bell-wright.com
This document must not be reproduced except in its entirety and with the express permission of Thomas Bell-Wright International Consultants
F 19 Scheme Certificate Issue 8 Issued Mar 2024



Scan for more info

FIXING SYSTEM (1) -Z CLEAT

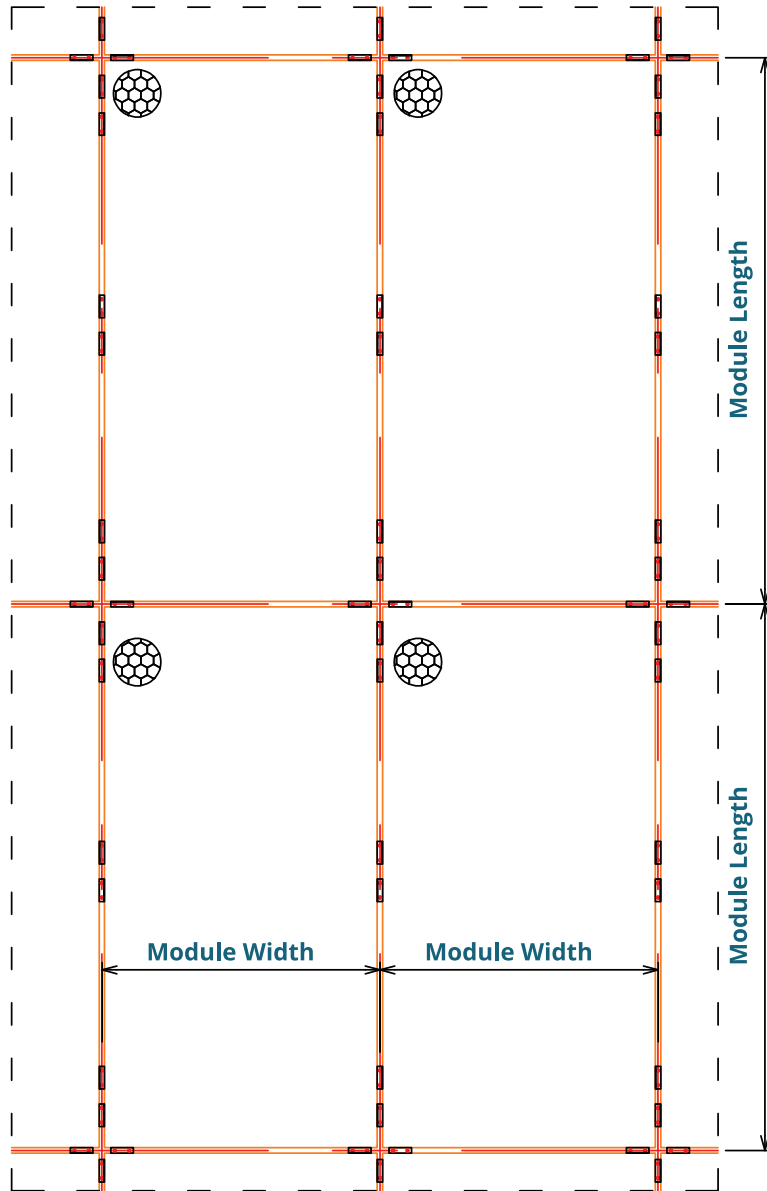

TYPICAL ELEVATION

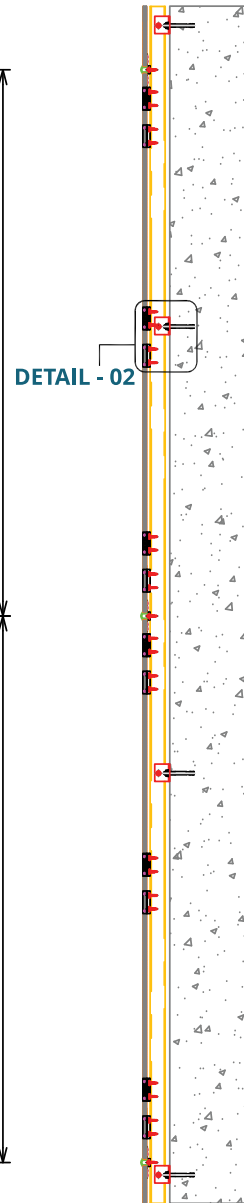

TYPICAL SECTION

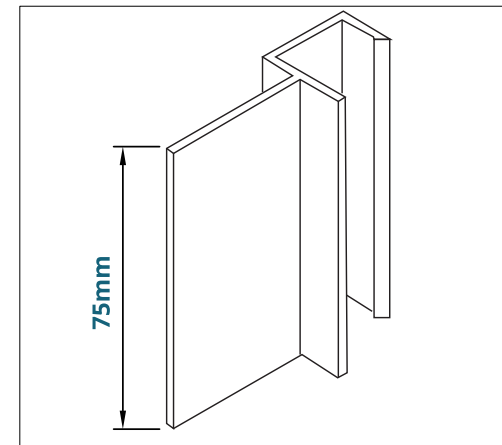

TYPICAL - ALMN "Z" CLEAT

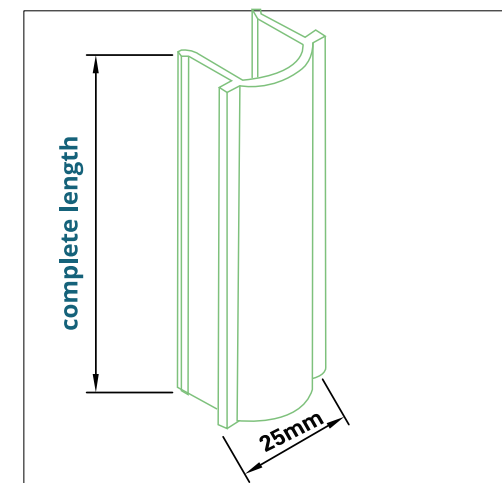

ALMN - COVERING PROFILE

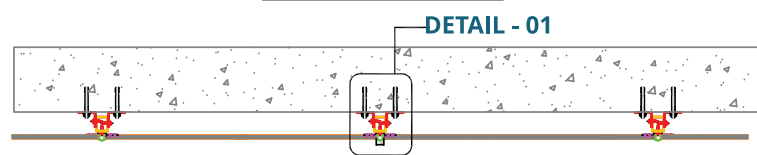

DETAIL - 01

ALUMINIUM- "Z" CLEAT SYSTEM

THINK CLADDING THINK

ALSTONE[®]

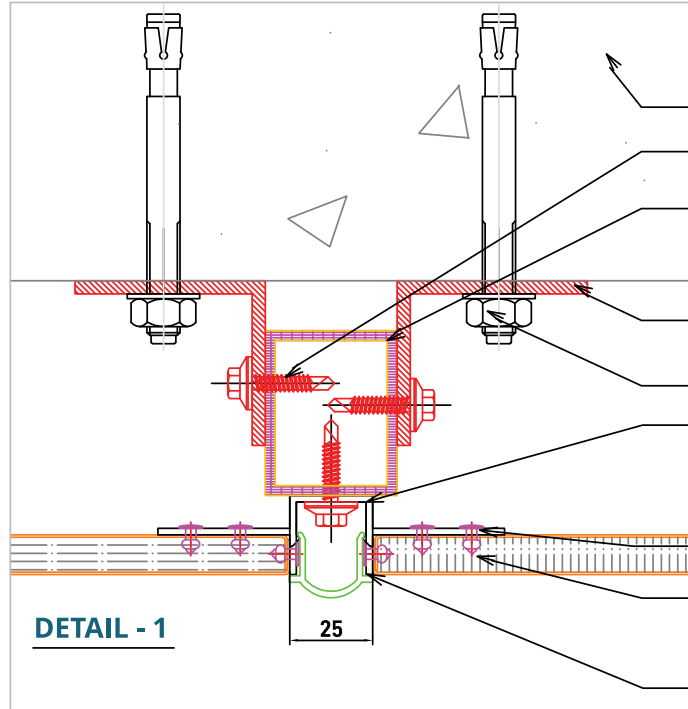
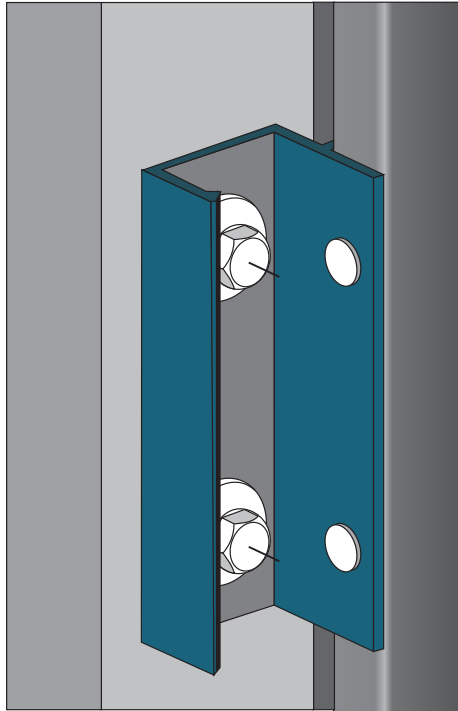

- SUB STRUCTURE
- SELF TAPPING SCREW
- ALUMINIUM EXTRUDED BOX SECTION
- MS L ANGLE IN STAGGERING FIXING SYSTEM
- ANCHOR BOLTS
- ALUMINIUM EXTRUDED "Z" CLEAT - CUSTOMIZED
- ALUMINIUM POP RIVETS
- HONEY COMB PANEL - 12mm THK
- ALUMINIUM EXTRUDED COVERING PROFILE

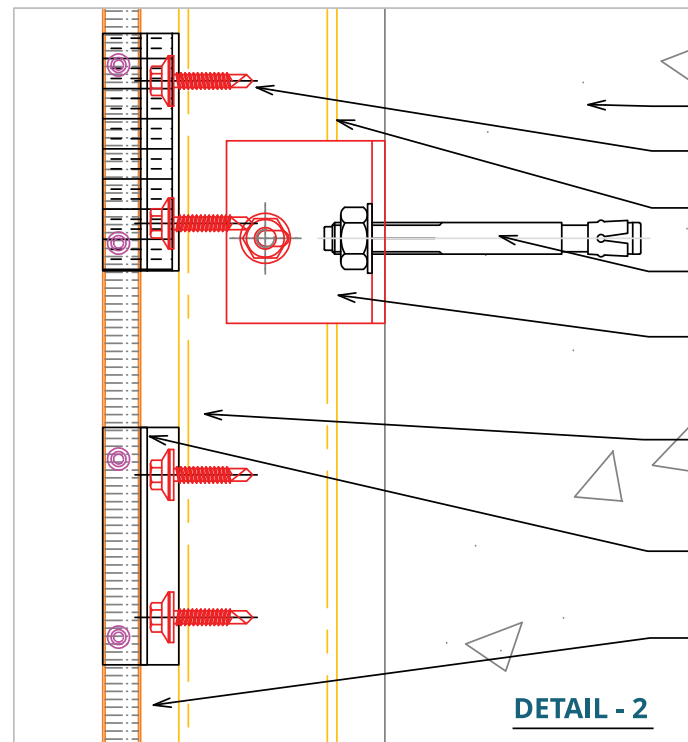
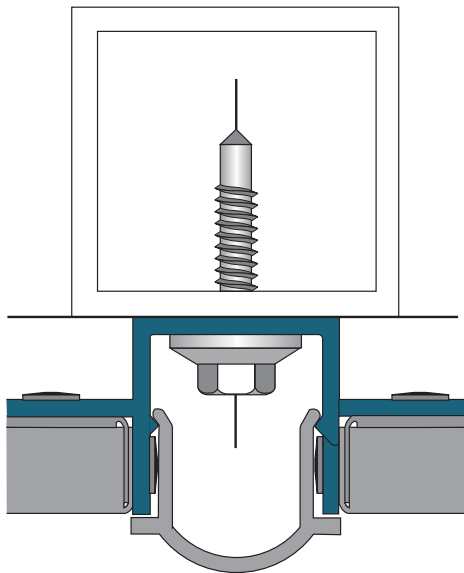

- SUB STRUCTURE
- SELF TAPPING SCREW
- ALUMINIUM EXTRUDED BOX SECTION
- ANCHOR BOLTS
- MS L ANGLE IN STAGGERING FIXING SYSTEM
- ALUMINIUM EXTRUDED "Z" CLEAT - CUSTOMIZED
- ALUMINIUM POP RIVETS
- HONEY COMB PANEL - 12mm THK



Scan for more info

FIXING SYSTEM (2) - HOOK ON

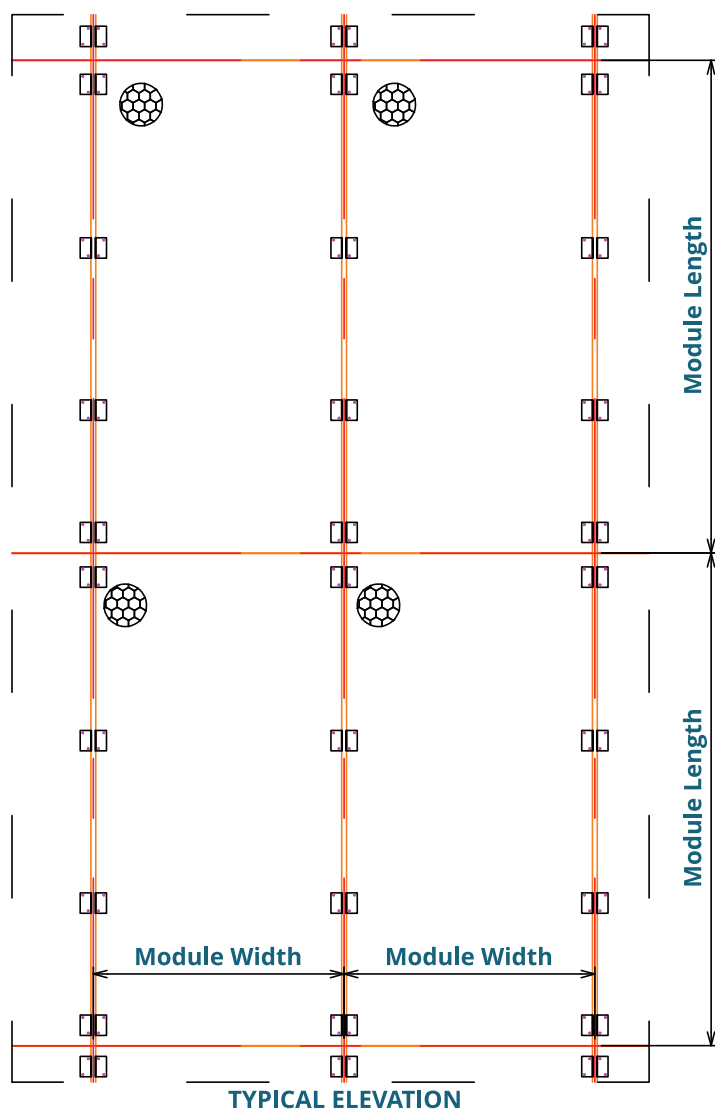

TYPICAL ELEVATION

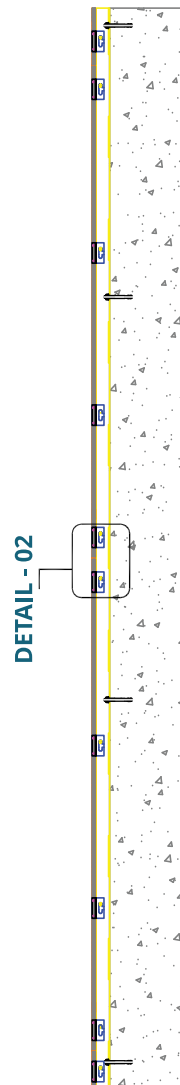

TYPICAL SECTION

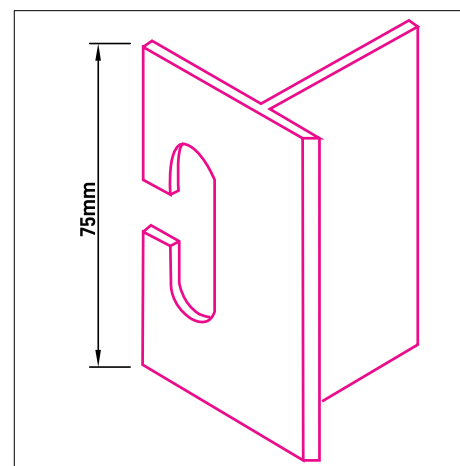

TYPICAL - ALMN SLOTTED HOOK ON

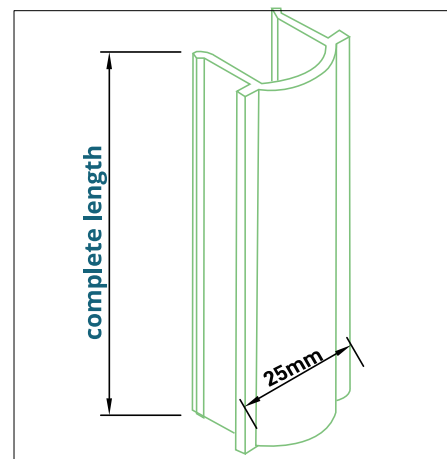

ALMN - COVERING PROFILE

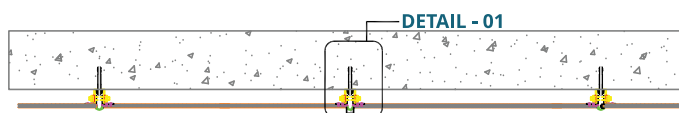

TYPICAL PLAN

ALUMINIUM- HOOK ON SYSTEM

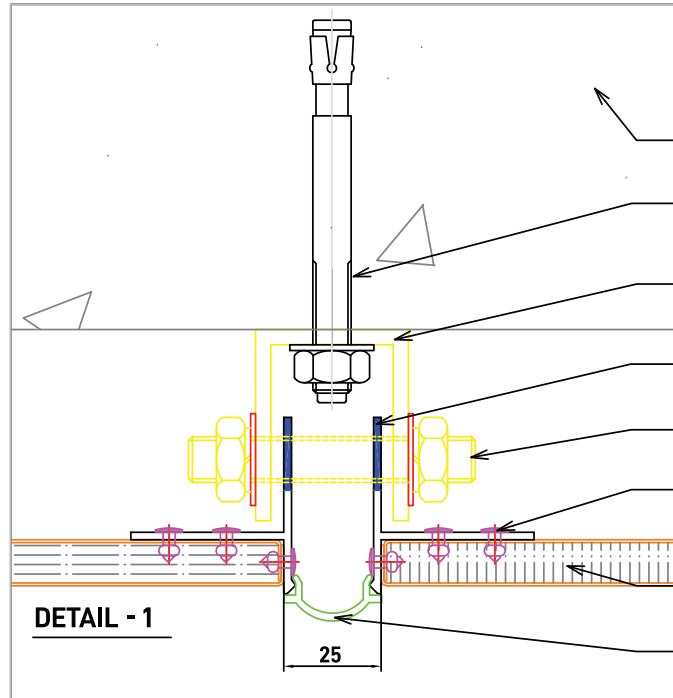
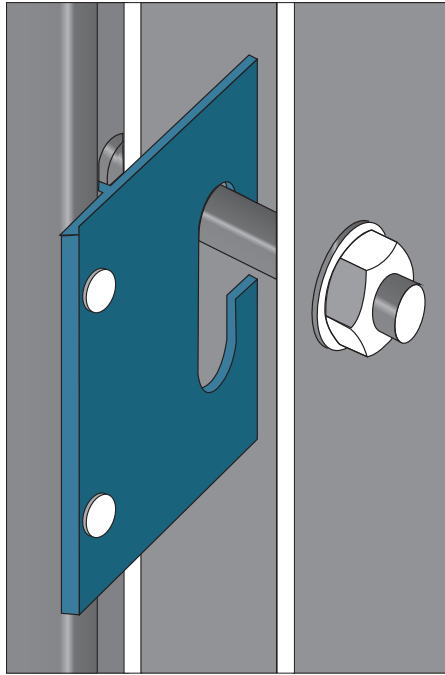

- SUB STRUCTURE
- ANCHOR BOLTS
- MS "U" CHANNEL SECTION - CONTINUOUS
- ALUMINIUM EXTRUDED - SLOTTED HOOK ON TYPE
- MS PLAIN SHANK BOLT & NUT
- ALUMINIUM POP RIVETS
- HONEY COMB PANEL - 12mm THK
- ALUMINIUM EXTRUDED COVERING PROFILE - # 2

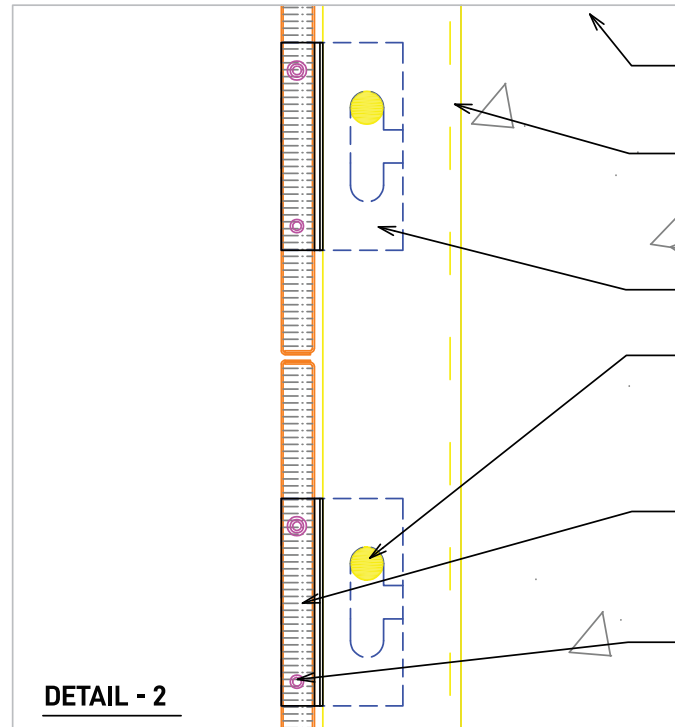
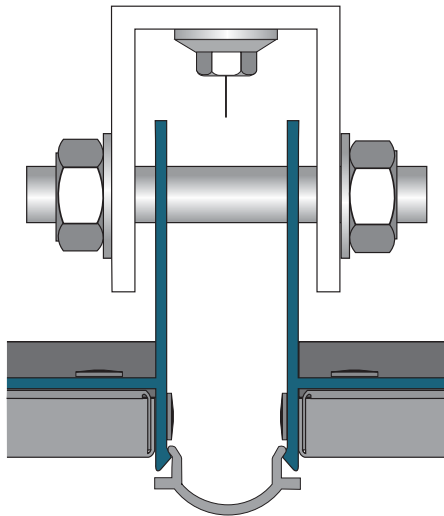

- SUB STRUCTURE
- MS "U" CHANNEL SECTION - CONTINUOUS
- ALUMINIUM EXTRUDED - SLOTTED HOOK ON TYPE
- MS PLAIN SHANK BOLT & NUT
- HONEY COMB PANEL - 12mm THK
- ALUMINIUM POP RIVETS

DETAIL - 2

TECHNICAL DATA SHEET- CLOSED PANEL ALLOY SPECIFICATION

ALLOY SPECIFICATIONS

Top & Bottom Coil	AA 3105	H16, H24
Honeycomb Core	AA 3003	H16

PANEL PROPERTIES

Panel Thickness	6mm to 200mm	± 0.5mm
Top Coil Thickness	1.0mm, 0.7mm	± 0.05mm
Bottom Coil Thickness	0.7mm, 0.05mm	± 0.05mm
Panel Width (Max)	1550mm	± 2mm
Panel Length (Max)	< 9000mm	± 2mm
Weight (12mm)	4.0 kg/m ²	± 0.2kg
Weight (25mm)	4.5 kg/m ²	± 0.2kg
U Value	5.58W/m ² K	

HONEYCOMB CORE PROPERTIES

Honeycomb Cell Size (D)	10mm to 20mm
Honeycomb Foil Thickness	0.076mm

GLUE

Two Component PU - Automatically Sprayed

***Cutomised Specifications Are Also Available on Request**

THINK | CLADDING | THINK

ALSTONE[®]

OUR PRODUCT RANGE

ALSTONE[®]
ZiNC
IN COLLABORATION WITH **VMZINC**

ALSTONE[®]
ALCOMB
Aluminium Honeycomb Panel

ALSTONE[®]
STONEARC

ALSTONE[®]
HPL
Feel The Nature

ALSTONE[®]
LOUVERS
LIMITLESS AS YOUR IMAGINATION

ALSTONE[®]
ANOMETA
ANODIZED LUXURY

ALSTONE[®]
Stonera
WORK OF ART

ALSTONE[®]
ANTICA
BEAUTIFULLY RUSTIC

ALSTONE[®]
3D PANELS

ALSTONE[®]
EVOLUTION
METAL COMPOSITE PANEL

ALSTONE[®]
CLASSIC
METAL COMPOSITE PANEL

ALSTONE[®]
Interio

ALSTONE[®]
SIGN PRO

ALSTONE[®]
FUEL PRO

ALSTONE[®] | BEAUTY THAT LASTS LONG
ALSTAR HPL

ALSTONE[®]
ALSTAR
ALUMINIUM COMPOSITE PANEL

ALSTONE®
Design
Café 3D

CUSTOMISED 3D PREVIEW
OF YOUR PROJECTS

***Super Batting,
Super Cladding!***

3.0



— OFFICIAL CLADDING PARTNER —



ALSTONE MANUFACTURING PVT. LTD.

Corporate Office

15th Floor, Vijaya Building.
17, Barakhamba Road.
Connaught Place, New
Delhi-110001

Plant

(Uttarakhand)

1393, Langha Road,
Industrial Area, Dehradun
Uttarakhand-248197

Plant

(Rajasthan)

RIICO industrial area,
Keshwana, District-Kotputli
Behror (Rajasthan)-303108

Branches

Ahmedabad | Bengaluru | Bhubneshwar | Chennai | Delhi | Hyderabad | Indore | Jaipur |
Kochi | Kolkata | Lucknow | Mumbai | Noida | Patna | Pune | Guwahati | Ranchi

CALL: 9599040030 | info@alstoneindia.com | www.alstoneindia.com | Follow us @alstonecladding



Scan for
more details